

Module 6

Image Compression

- Lossless Image Coding
- Lossy Image Coding
- JPEG Image Compression Standards
- Wavelet Compression

OBJECTIVES OF IMAGE COMPRESSION

- Create a **compressed** image that "looks the same" (when **decompressed**) but can be stored in a fraction of the space.
- **Lossless compression** means the image can be **exactly** reconstructed.
- **Lossy compression** means that **visually redundant** information is removed. The decompressed image "looks" unchanged, but mathematically has lost information.
- **Image compression** is important for:
 - Reducing image **storage space**
 - Reducing image **transmission bandwidth**

Significance for Storage & Transmission

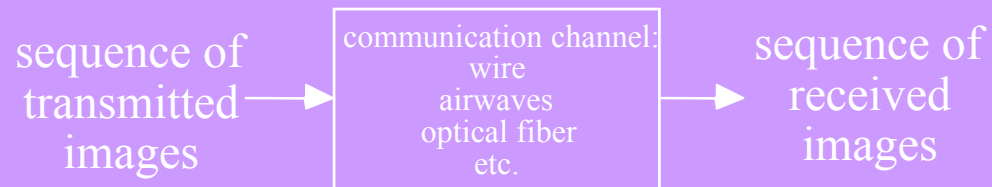
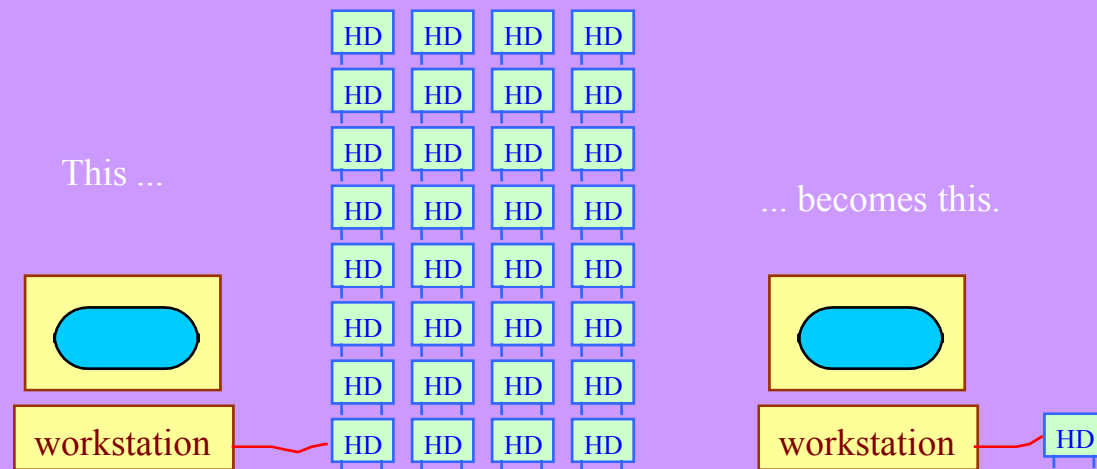

Compressed images can be sent at an increased rate: **More images per second !**

DILBERT

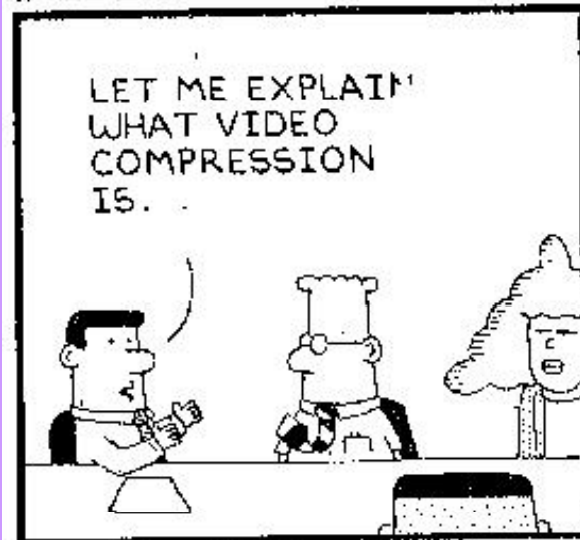

www.dilbert.com scottadams@aol.com

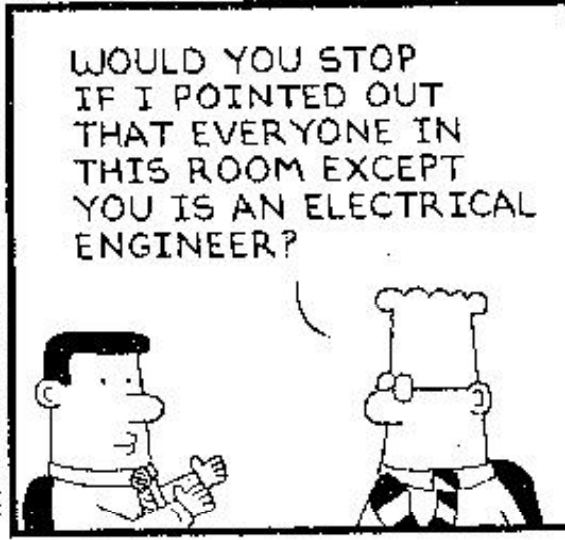

©2004 Scott Adams, Inc./Dist. by UFS, Inc.

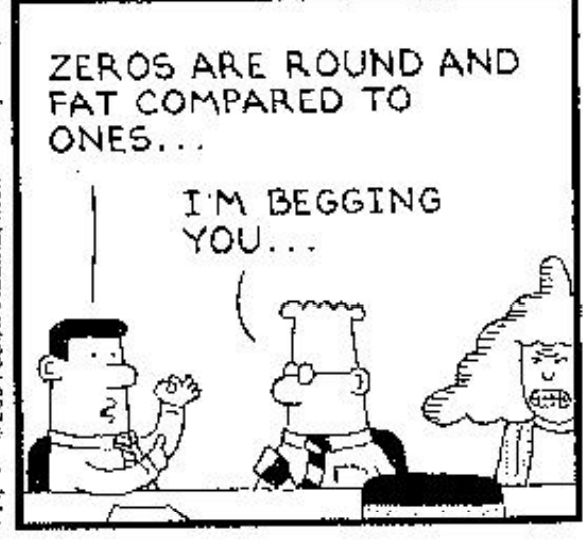

Lossless Image Compression

Image Compression Measures

- **Bits Per Pixel (BPP)** is the **average** number of bits required to store the gray level of each pixel in I.

- **Uncompressed image** (K is gray scale range):

$$\text{BPP}(\mathbf{I}) = \log_2(\mathbf{K}) = \mathbf{B}$$

- Usually

$$\mathbf{B} = \log_2(256) = 8.$$

Variable-Bit Codes

- The number of bits used to code pixels may **spatially vary**.
- Suppose that $\hat{\mathbf{I}}$ is a compressed version of \mathbf{I} .
- Let $B(i, j) = \#$ of bits used to code pixel $\mathbf{I}(i, j)$. Then

$$\text{BPP}(\hat{\mathbf{I}}) = \frac{1}{NM} \sum_{i=0}^{N-1} \sum_{j=0}^{M-1} B(i, j)$$

- If **total** number of bits in $\hat{\mathbf{I}}$ is B_{total} , then

$$\text{BPP}(\hat{\mathbf{I}}) = \frac{1}{NM} B_{\text{total}}$$

Compression Ratio

- The **Compression Ratio (CR)** is

$$CR = \frac{BPP(I)}{BPP(\hat{I})} > 1$$

- Both **BPP** and **CR** are used frequently.

LOSSLESS IMAGE COMPRESSION

- **Lossless** techniques achieve compression with **no loss of information**.
- The true image can be reconstructed **exactly** from the coded image.
- Lossless coding doesn't usually achieve **high compression** but has definite applications:
 - In **combination** with lossy compression, multiplying the gains
 - In applications where information loss is **unacceptable**.
- Lossless compression ratios **usually** in the range

$$2:1 \leq CR \leq 3:1$$

but this may vary from image to image.

Methods for Lossless Coding

- Basically amounts to clever arrangement of the data.
- This can be done in many ways and in many domains (DFT, DCT, wavelet, etc)
- The most popular methods use **variable wordlength coding**.

Variable Wordlength Coding

(Huffman Code)

Variable Wordlength Coding (VWC)

- **Idea**: Use **variable wordlengths** to code gray levels.
- Assign **short wordlengths** to gray levels that occur **frequently** (redundant gray levels).
- Assign **long wordlengths** to gray levels that occur **infrequently**.
- On the average, the **BPP will be reduced**.

Image Histogram and VWC

- Recall the **image histogram** H_I :

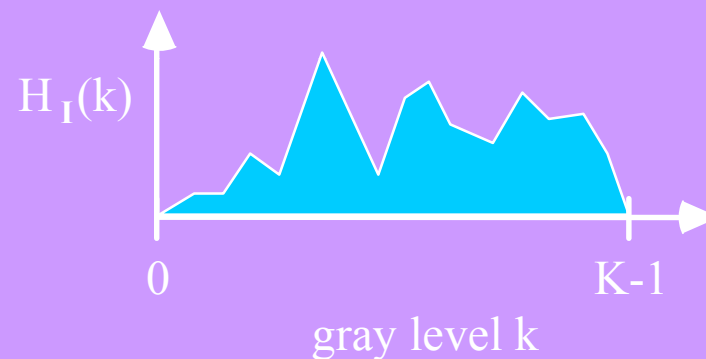

- Let $B(k) = \#$ of bits used to code gray-level k . Then

$$\text{BPP}(\hat{I}) = \frac{1}{NM} \sum_{k=0}^{K-1} B(k)H_I(k)$$

- This is the **common measure of BPP for VWC**.₁₃

Image Entropy

- Recall the **normalized histogram** values

$$p_I(k) = \frac{1}{NM} H_I(k) ; k=0, \dots, K-1$$

so $p_I(k)$ = probability of gray level k

- The **entropy** of image I is then

$$E[I] = - \sum_{k=0}^{K-1} p_I(k) \log_2 p_I(k)$$

Meaning of Entropy

- **Entropy** is a **measure of information** with nice properties for designing VWC algorithms.
- **Entropy** $E[I]$ measures
 - **Complexity**
 - **Information Content**
 - **Randomness**

Maximum Entropy Image

- The entropy is **maximized** when

$$p_I(k) = \frac{1}{K} ; k=0, \dots, K-1$$

corresponding to a **flat histogram**. Then ($K = 2^B$)

$$E[I] = - \sum_{k=0}^{K-1} \frac{1}{K} \log_2 \frac{1}{K} = B \cdot \sum_{k=0}^{K-1} \frac{1}{K} = B$$

- Generally, image entropy increases as the histogram is spread out.

Minimum Entropy Image

- The entropy is **minimized** when

$$p_I(k_n) = 1 \text{ for some } k_n ; 0 \leq k_n \leq K-1$$

hence $p_I(k_m) = 0$ for $m \neq n$.

- This is a **constant image** and $E [I] = 0$.
- In fact it is always true that

$$0 \leq E [I] \leq B$$

Significance of Entropy

- An important **theorem** limits **how much** an image can be compressed by a lossless VWC:

$$\text{BPP}(\hat{\mathbf{I}}) \geq E[\mathbf{I}]$$

- A VWC is assumed **uniquely decodable**.
- The $p_{\mathbf{I}}(k)$ are assumed known at both transmitter **and** receiver.
- Thus an image with a flat histogram: $E[\mathbf{I}] = B$ **cannot be compressed** by a VWC alone. Fortunately, we can often fix this situation by **entropy reduction**.
- Moreover, a **constant image** need not be sent: $E[\mathbf{I}] = 0!$
- The entropy provides a compression **lower bound** as a **target**.

Image Entropy Reduction

- **Idea:** Compute a new image **D** with a more compressed histogram than **I** but with no loss of information.

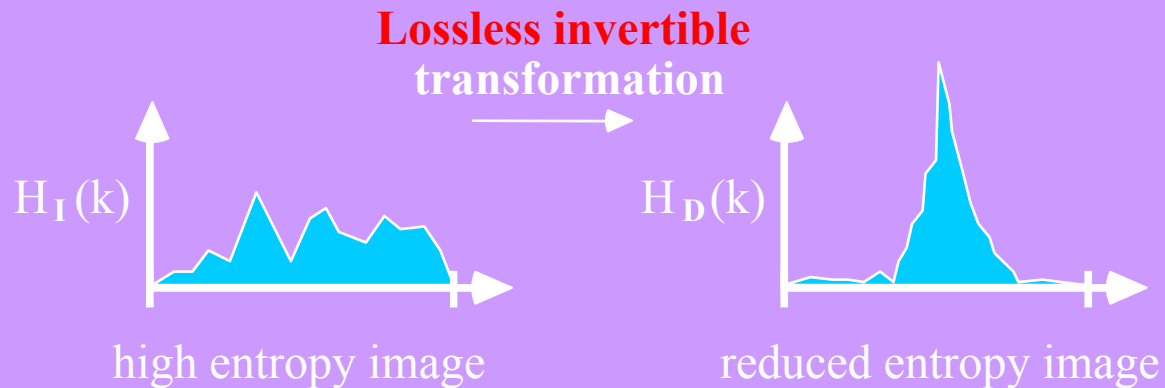

- Must be able to recover **I exactly** from **D** - **no loss** of information.
- **Compressing** the histogram (Module 3) won't work, since information is lost when two gray levels k_1 and k_2 are mapped to the same new gray level k_3 .

Entropy Reduction by Differencing (Simple DPCM)

- **Differential pulse-code modulation (DPCM)** is effective for lossless image entropy reduction.
- Images are mostly smooth: neighboring pixels **often** have similar values.
- Define a **difference image D** using either 1-D or 2-D differencing:
(1-D) $D(i, j) = I(i, j) - I(i, j-1)$
(2-D) $D(i, j) = I(i, j) - I(i-1, j) - I(i, j-1) + I(i-1, j-1)$
for $0 \leq i \leq N-1, 1 \leq j \leq M-1$.
- The new histogram H_D usually will be more compressed than H_I , so that

$$E[D] < E[I]$$

- This is a rule of thumb for images, not a math result.

Reversing DPCM

- If (1) is used, then

$$I(i, j) = D(i, j) + I(i, j-1)$$

- The **first column** of I must also be transmitted.

- If (2) is used, then

$$I(i, j) = D(i, j) + I(i-1, j) + I(i, j-1) - I(i-1, j-1)$$

where the first row and first column of I must also be transmitted.

- The overhead of the first row and column is small, but they can be **separately compressed**.
- **Hereafter** we will assume an image I has either been histogram compressed by DPCM or doesn't need to be.

Optimal Variable Wordlength Code

- **Recall** the theoretical **lower bound** using a VWC:

$$\text{BPP}(\hat{\mathbf{I}}) \geq E[\mathbf{I}] = - \sum_{k=0}^{K-1} p_{\mathbf{I}}(k) \log_2 p_{\mathbf{I}}(k)$$

- Observe: In any VWC, coding each gray-level k using **wordlength** $L(k)$ bits gives an **average wordlength**:

$$\text{BPP}(\hat{\mathbf{I}}) = \sum_{k=0}^{K-1} p_{\mathbf{I}}(k) L(k)$$

- Compare with the above. If $L(k) = -\log_2 p_{\mathbf{I}}(k)$ then an optimum code has been found - lower bound attained!

Optimal VWC

- **IF** we can find such a VWC such that

$$L(k) = -\log_2 p_I(k) \text{ for } k = 0, \dots, K-1$$

then the code is **optimal**.

- It is impossible if $-\log_2 p_I(k) \neq$ an integer for **some** k .
- So: define an **optimal code** \hat{I} as one that satisfies:
 - $BPP(\hat{I}) \leq BPP(\hat{I}')$ of any other code \hat{I}'
 - $BPP(\hat{I}) = E[I]$ if $[-\log_2 p_I(k)] =$ integers

The Huffman Code

- The **Huffman algorithm** yields an **optimum code**.
- For a set of gray levels $\{0, \dots, K-1\}$ it gives a set of **code words** $c(k)$; $0 \leq k \leq K-1$ such that

$$\text{BPP}(\hat{\mathbf{I}}) = \sum_{k=0}^{K-1} p_{\mathbf{I}}(k) L[c(k)]$$

is the **smallest possible**.

Huffman Algorithm

- Form a **binary tree** with branches labeled by the gray-levels k_m and their probabilities $p_I(k_m)$:
 - (0) Eliminate any k_m where $p_I(k_m) = 0$.
 - (1) Find 2 **smallest probabilities** $p_m = p_I(k_m)$, $p_n = p_I(k_n)$.
 - (2) Replace by $p_{mn} = p_m + p_n$ to **form a node**; reduce list by 1
 - (3) Label the branch for k_m with (e.g.) '1' and for k_n with '0'.
 - (4) Until list has only 1 element (root reached), return to (1).
- In step (3), values '1' and '0' are assigned to element pairs (k_m, k_n) , elements triples, etc. as the process progresses.

Huffman Tree Example 1

- There are $K = 8$ values $\{0, \dots, 7\}$ to be assigned codewords:

$$p_I(0) = 1/2$$

$$p_I(4) = 1/16$$

$$p_I(1) = 1/8$$

$$p_I(5) = 1/32$$

$$p_I(2) = 1/8$$

$$p_I(6) = 1/32$$

$$p_I(3) = 1/8$$

$$p_I(7) = 0$$

- The process creates a **binary tree**, with values '1' and '0' placed (e.g.) on the right and left branches at each stage:

Huffman Tree Example 1

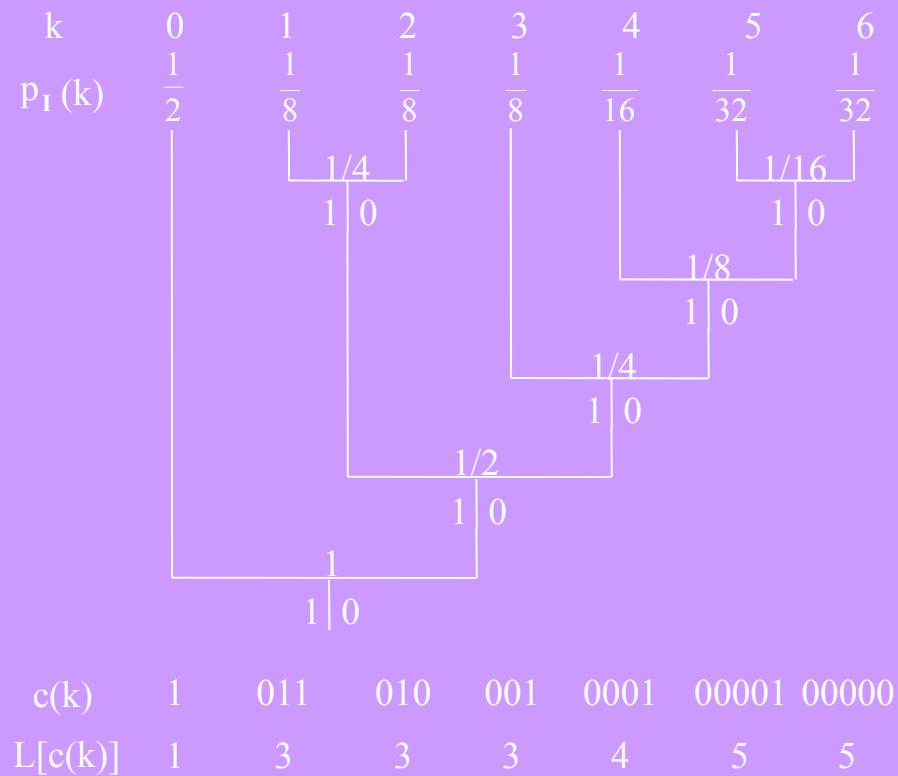

BPP = Entropy = 2.1875 bits
CR = 1.37 : 1

Huffman Tree Example 2

- There are $K = 8$ values $\{0, \dots, 7\}$ to be assigned codewords:

$$p_I(0) = 0.4$$

$$p_I(4) = 0.12$$

$$p_I(1) = 0.08$$

$$p_I(5) = 0.08$$

$$p_I(2) = 0.08$$

$$p_I(6) = 0.04$$

$$p_I(3) = 0.2$$

$$p_I(7) = 0.00$$

Huffman Tree Example 2

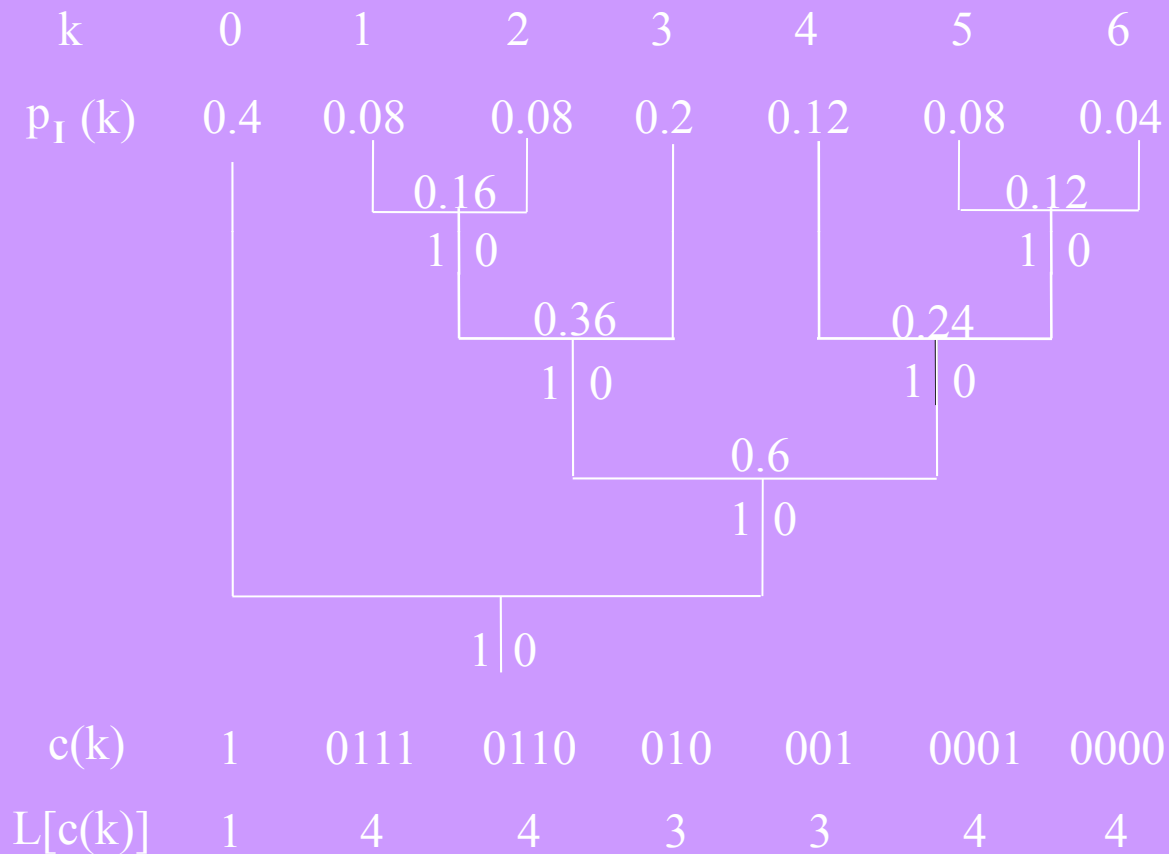

BPP = 2.48 bits
 Entropy = 2.42 bits
 CR = 1.2 : 1

Huffman Decoding

- The Huffman code is a **uniquely decodable** code. There is **only one interpretation** for a series of codewords (series of bits).
- Decoding progresses by **traversing the tree**.

Huffman Decoding Example

- In the **second example**, this sequence is received:

00010110101110000010000100010110111010

- It is sequentially examined until a codeword is identified. This continues until all are identified:

0001 0110 1 0111 0000 010 0001 0001 0110 1 1 1 010

- The decoded sequence is: 5 2 0 1 6 3 5 5 2 0 0 0 3

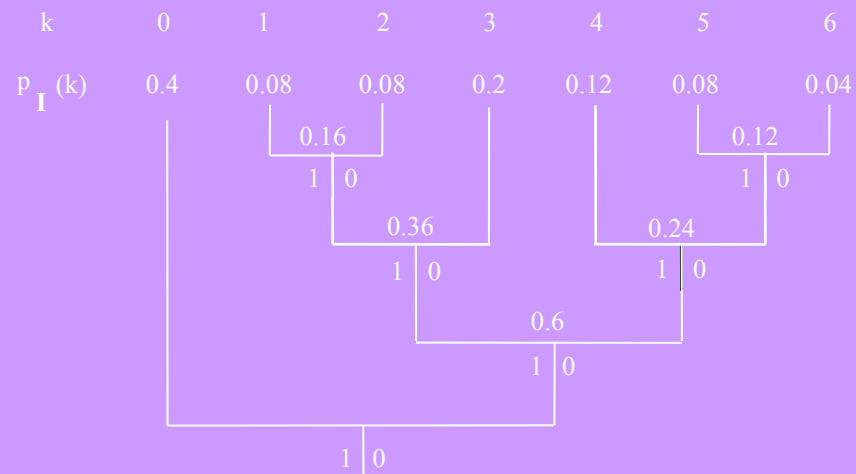

Comments on Huffman Coding

- **Huffman image compression** usually
 $2:1 \leq CR \leq 3:1$
- Huffman codes are quite **noise-sensitive** (much more so than an uncompressed image).
- **Error-correction coding** can improve this but increases increase the coding rate somewhat.
- Some Huffman codes aren't computed from the image statistics - instead **assume** "typical" frequencies of occurrence of values (gray-level or transform values) – as in JPEG.

Lossy Image Compression

LOSSY IMAGE CODING

- **Many** approaches proposed.
- We will review a **few** popular approaches.
 - **Block Truncation Coding** (BTC) – simple, fast
 - **Vector Quantization Coding** (VQC) - costly but high-quality results
 - **Discrete Cosine Transform** (DCT) Coding and the **JPEG Standard**
 - **Wavelet Image Coding** and **JPEG-2000**

History of Image Compression Advances

- The **compression ratios** obtained over the first 30 years of research:

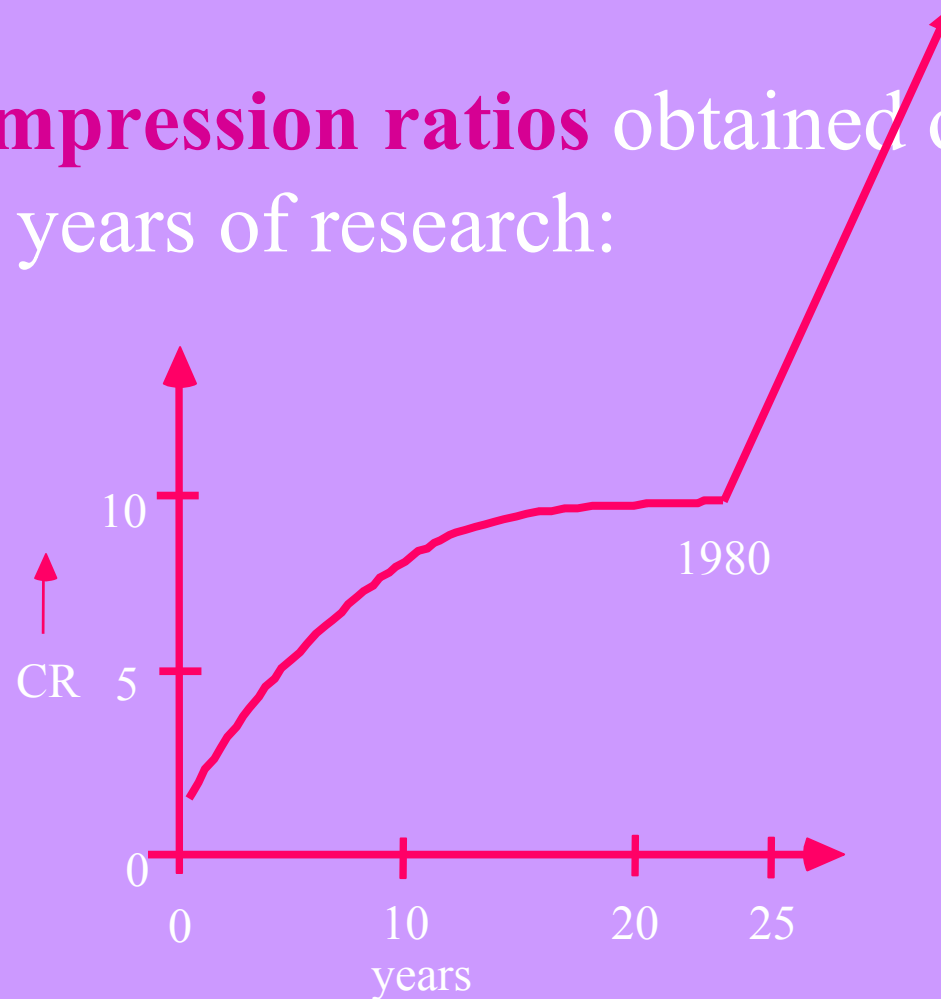

Goals of Lossy Coding

- To optimize and balance the three C's
 - **Compression** achieved by coding
 - **Computation** required by coding and decoding
 - **Cuality** of the decompressed image

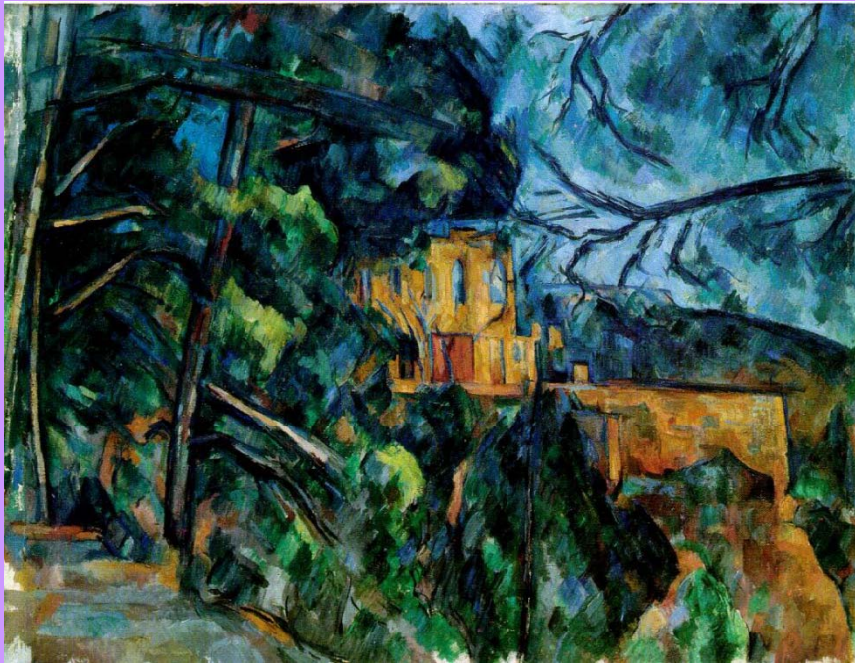

Artistic image coding with significant loss
(Cezanne)



Artistic image coding with little loss
(Degas)

Broad Methodology of Lossy Compression

- There have been **many** proposed lossy compression methods.
- The successful broadly (and loosely) follow three steps.
 - (1) Transform the image to another domain and/or extract specific features.
 - (2) Quantize in this domain or those features.
 - (3) Efficiently organize and/or entropy code the quantized data.

Block Coding of Images

- **Most** lossy methods begin by partitioning the image into **sub-blocks** that are individually coded. **Wavelet methods** are an **exception**.

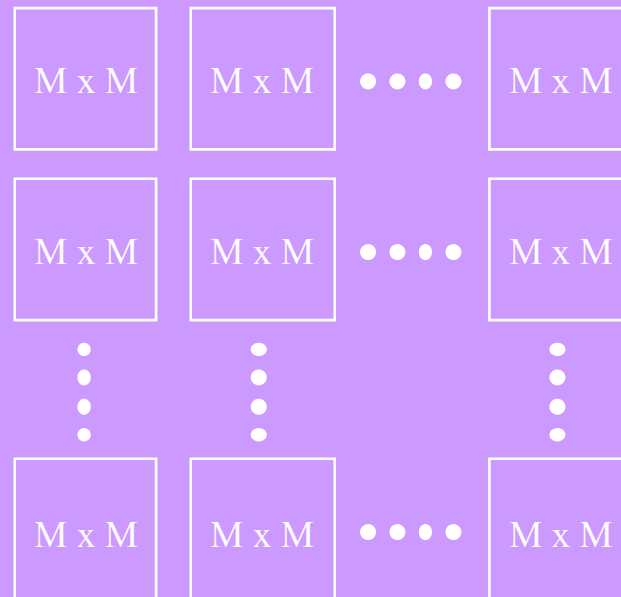

Why Block Coding?

- Reason: images are **highly nonstationary**: **different areas** of an image may have **different properties**, e.g., more high or low frequencies, more or less detail etc.
- Thus, **local coding** is **more efficient**. Wavelet methods provide localization without blocks.
- Typical block sizes: **4 x 4, 8 x 8, 16 x 16**.

Block Truncation Coding (BTC)

Block Truncation Coding (BTC)

- **Fast**, but limited compression.
- Uses **4 x 4 blocks** each containing $16 \cdot 8 = \mathbf{128 \text{ bits}}$.
- Each 4 x 4 block is coded identically so no need to **index them**.
- Consider the coding of a **single block** which we will denote $\{I(1), \dots, I(16)\}$.

BTC Coding Algorithm

(1) Quantize **block sample mean**:

$$\bar{I} = \frac{1}{16} \sum_{p=1}^{16} I(p)$$

and transmit/store it with B_1 bits.

(2) Quantize **block sample standard deviation**:

$$\bar{\sigma}_I = \sqrt{\frac{1}{16} \sum_{p=1}^{16} [I(p) - \bar{I}]^2}$$

and transmit/store it with B_2 bits.

BTC Coding Algorithm

- Compute a **16-bit binary block**:

$$b(p) = \begin{cases} 1 & ; \text{ if } I(p) \geq \bar{I} \\ 0 & ; \text{ if } I(p) < \bar{I} \end{cases}$$

121	114	56	47
37	200	247	255
16	0	12	169
43	5	7	251

$\bar{I} = 98.75$
→

1	1	0	0
0	1	1	1
0	0	0	1
0	0	0	1

which requires 16 bits to transmit/store.

BTC Quantization

- The quality/compression of BTC-coded images depends on the **quantization** of mean and standard deviation.
- If $B_1 = B_2 = 8$, 32 bits / block are transmitted:
$$CR = 128 / 32 = 4:1$$
- OK quality if $B_1 = 6, B_2 = 4$ (26 bits total):
$$CR = 128 / 26 \approx 5:1$$
- Using $B_1 > B_2$ is OK: the eye is quite sensitive to the **presence** of variation, but **not** to the **magnitude** of variation:

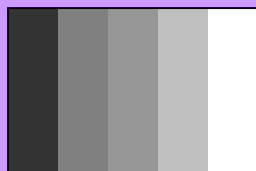

Mach Band Illusion

BTC Block Decoding

- To form the "decoded" pixels $J(1) , \dots, J(16)$:
 - (1) Let Q = number of '1's, P = number of '0's in binary block.
 - (2) If $\begin{cases} b(p)=1 & ; \text{ set } J(p) = \bar{I} + \bar{\sigma}_I/A \\ b(p)=0 & ; \text{ set } J(p) = \bar{I} - \bar{\sigma}_I \cdot A \end{cases}$

where

$$A = \sqrt{\frac{Q}{P}}$$

- It is possible to show that this forces $\bar{J} \approx \bar{I}$ and $\bar{\sigma}_J \approx \bar{\sigma}_I$

BTC Block Decoding Example

- In our example: $Q = 7, P = 9, A = 0.8819$

$$\bar{I} = \text{INT}[98.75 + 0.5] = 99$$

$$\bar{\sigma}_I = \text{INT}[92.95 + 0.5] = 93$$

- If $\begin{cases} b(p)=1 & ; \text{ set } J(p) = 99 + \text{INT}[93/0.882+0.5] = 204 \\ b(p)=0 & ; \text{ set } J(p) = 99 - \text{INT}[93 \cdot 0.882+0.5] = 17 \end{cases}$

204	204	17	17
17	204	204	204
17	17	17	204
17	17	17	204

Here $\bar{J} \approx 98.8$

$\bar{\sigma}_J \approx 77.3$

DEMO

Comments on BTC

- Attainable compressions by simple BTC in the range 4:1 – 5:1.
- Combining with **entropy coding** of the quantized data, in the range 10:1.
- Popular in **low-bandwidth, low-complexity** applications. Used by the Mars Pathfinder!

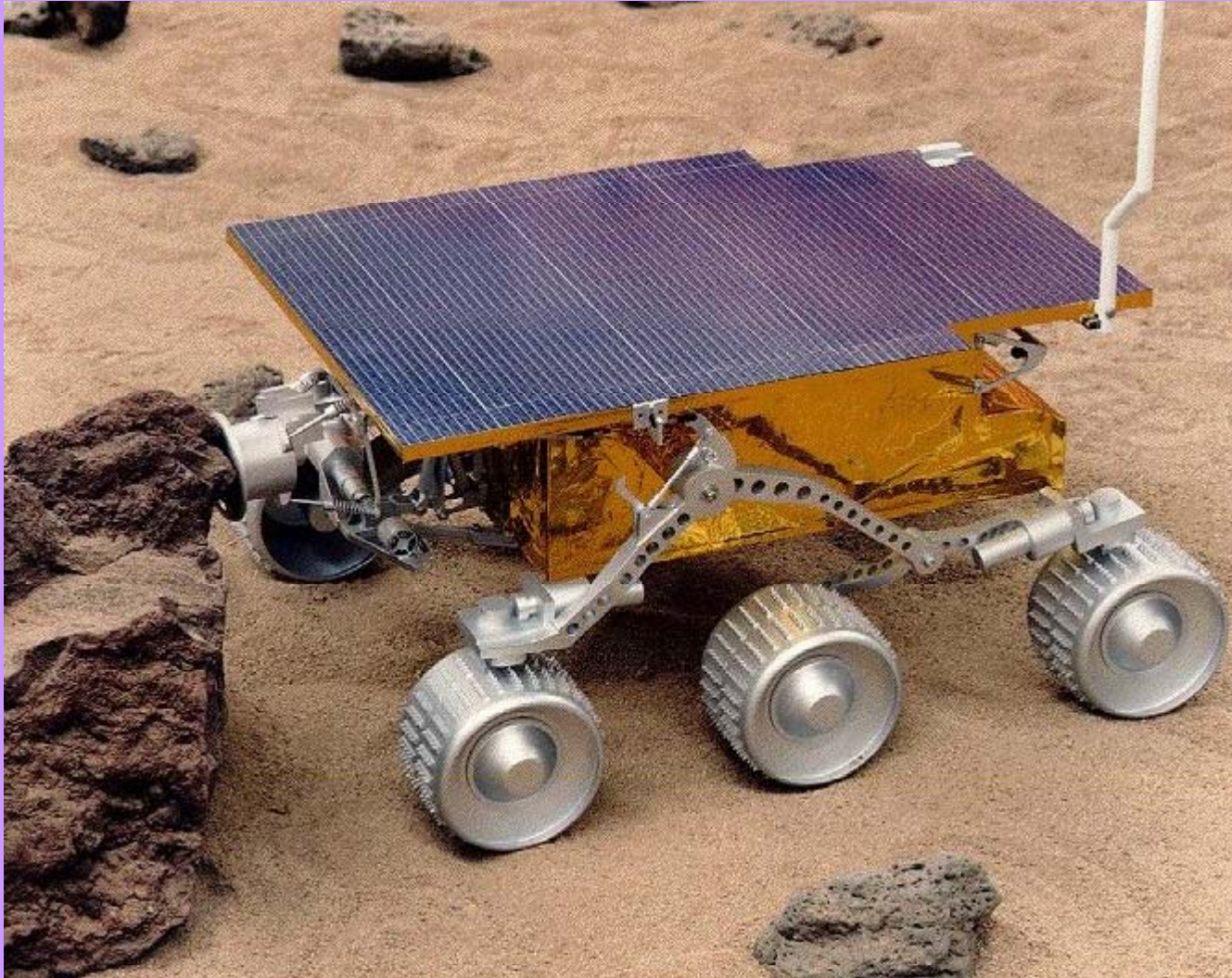

Vector Quantization Image Compression

Vector Quantization Image Coding

- A very light overview!
- Actually, there are **many variations** of this technique.
- **Coding** via VQ is **very computation-intensive**. **Decoding** is not.
- VQ algorithms also (usually) use **4 x 4 blocks** — each of which is coded identically.

VQ Codebook

- The image I is broken into 4×4 blocks \mathbf{b}_m ; $m = 1, \dots, MN/16$.
- From these, compute a **codebook** of P "typical" 4×4 blocks \mathbf{t}_p , $p = 1, \dots, P$.
- This is done using a **clustering algorithm** which divides a space of points into likely groups according to a distance criterion.
- Usually $256 \leq P \leq 1024$.
- Simplest: Use K-Means Clustering with $K=P$.

K-Means: Simple Clustering Method

- Given $MN/16$ **16-D** 4×4 blocks \mathbf{b}_m ; $m = 1, \dots, MN/16$.
- Partition** \mathbf{b}_m into **K 16-D clusters** $\mathbf{C} = \{C_1, C_2, \dots, C_K\}$ by minimizing the **within-cluster sum-of-squares**:

$$\arg \min_{\mathbf{C}} \sum_{k=1}^K \sum_{\mathbf{b}_j \in C_k} \|\mathbf{b}_j - \bar{\mathbf{b}}_k\|^2$$

where the $\bar{\mathbf{b}}_k$ are the **block means** (centroids).

- Lloyd's Algorithm:** Select initial means $\{\bar{\mathbf{b}}_1^{(0)}, \bar{\mathbf{b}}_2^{(0)}, \dots, \bar{\mathbf{b}}_K^{(0)}\}$ (e.g. randomly from the \mathbf{b}_m). Then iterate between two steps:
 - Assign \mathbf{b}_m ; $m = 1, \dots, MN/16$ to cluster q with mean $\bar{\mathbf{b}}_q^{(0)}$ closest to \mathbf{b}_m .
 - Calculate new cluster means

$$\bar{\mathbf{b}}_k^{(r+1)} = \frac{1}{\text{card}[C_k^{(r)}]} \sum_{\mathbf{b}_j \in C_k^{(r)}} \mathbf{b}_j$$

- Complexity:** $O\left[\left(\frac{MN}{16}\right)^{16P+1} \log\left(\frac{MN}{16}\right)\right]$

2 x 1 Codebook Example

- If 2 x 1 blocks were used, the space might look like this:

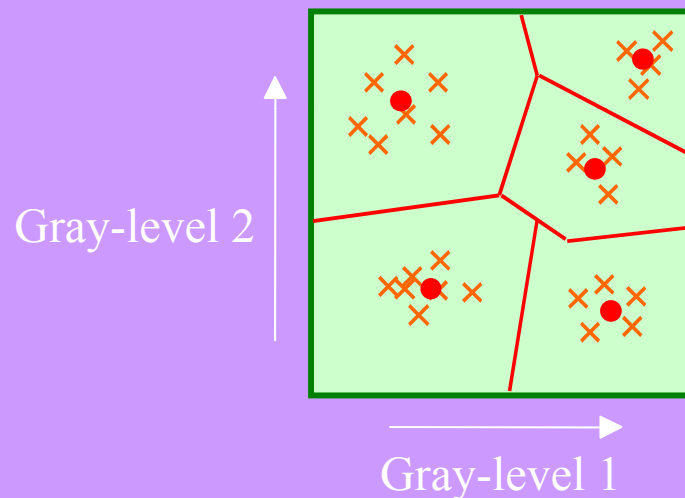

- The cluster **centroids** are the coordinates of the “typical” blocks!
- In VQ image compression, the space is **16-D**, rather than 2-D.

Codebook Computation

- Computation of the codebook directly from the image is **very time-consuming**.
- **Unrealistic for real-time encoding**.
- **Approximate** (sub-optimal) algorithms exist which are faster – e.g., Equitz Algorithm.
- A "**universal**" **codebook** can be used in applications where the images are always similar. Compute the codebook once from many images, then don't change it.

Codebook Search

- If codebook is computed from \mathbf{I} , finding the centroid of the cluster that block \mathbf{b} belongs to is **simple**.
- If a universal codebook is used, then the closest centroid must be **searched for**.
- The typical block \mathbf{t}_{q^*} is found that is closest to \mathbf{b} :

$$q^* = \arg \min_q \sqrt{\frac{1}{16} \sum_{p=1}^{16} [b(p) - t_q(p)]^2}$$

- The index q^* is the **code** for \mathbf{b} ! This is what is stored or transmitted.

VQ Decoding

- While codebook construction and search are very time consuming
- Decoding is **very fast!** Just a codebook look-up!
- Of course the codebook is **known by the decoder** (communications scenario).
- Given a code (index) q for block \mathbf{b} , the typical code \mathbf{t}_q represents \mathbf{b} in the **decompressed image**.

VQ Comments

- VQ is an excellent example of an **unbalanced codec** (coder-decoder).
- Great for apps where coding time is less important but **decoding time is very important**: e.g., image libraries.
- Compression ratios $CR = 15:1 - 20:1$ are **typical**.

Simple VQ Example 1

Original *Kevin*



16 : 1

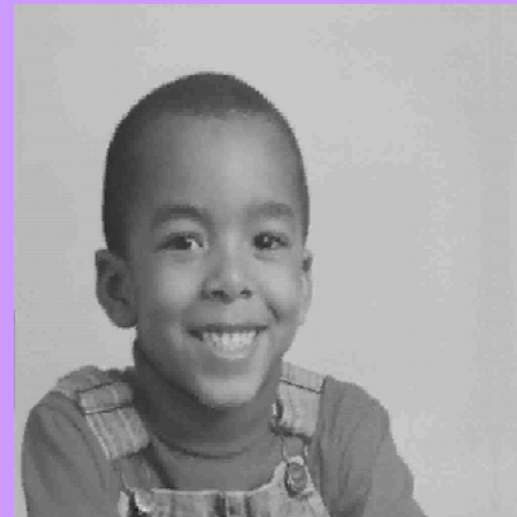

32 : 1

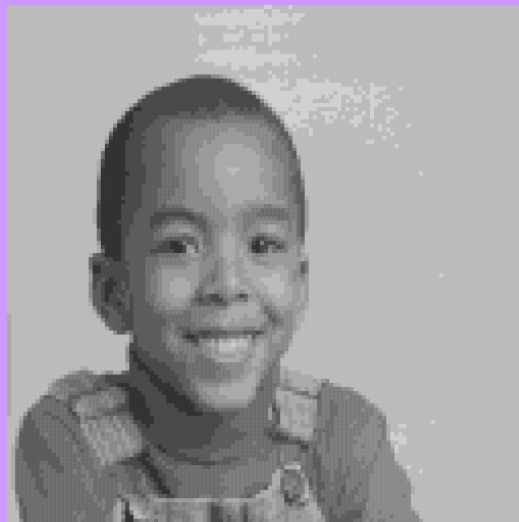

64 : 1



Simple VQ Example 2

Original *Steven*

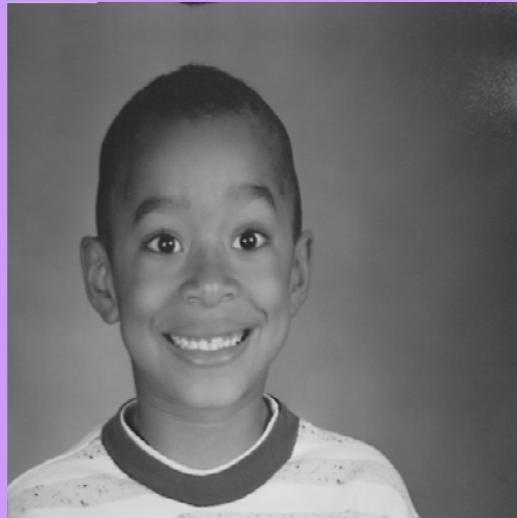

16 : 1

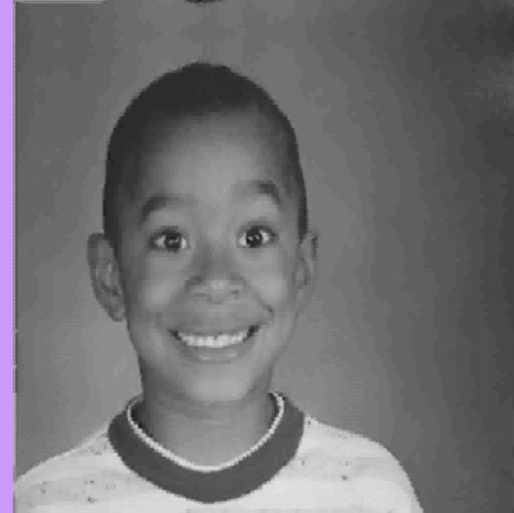

32 : 1



64 : 1

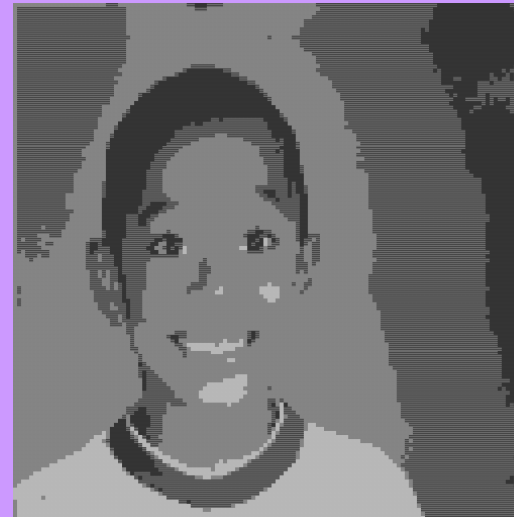

Classified VQ

- One effective variation is **classified VQ** where the block means and standard deviations are computed, and the blocks normalized by them:

$$\beta(p) = \frac{b(p) - \bar{b}}{\bar{\sigma}_b}$$

- The moments \bar{b} and $\bar{\sigma}_b$ are quantized and stored/transmitted **separately**.
- VQ is applied to the normalized blocks β to form a “classified codebook” which can be much smaller or more accurate.

JPEG

JPEG

- The **JPEG Standard** remains the most widely-used method of compressing images.
- JPEG = **Joint Photographic Experts Group**, an international standardization committee.
- Standardization allows device and software manufacturers to have an **agreed-upon format** for compressed images.
- In this way, everyone can “talk” and “share” images.
- The overall JPEG Standard is quite complex, but the core algorithm is based on the **Discrete Cosine Transform (DCT)**.

Discrete Cosine Transform (DCT)

- The **DCT** of an $N \times M$ image or sub-image:

$$\tilde{I}(u, v) = \frac{4C_N(u)C_M(v)}{NM} \sum_{i=0}^{N-1} \sum_{j=0}^{M-1} I(i, j) \cos\left[\frac{(2i+1)u\pi}{2N}\right] \cos\left[\frac{(2j+1)v\pi}{2M}\right]$$

- The **IDCT**:

$$I(i, j) = \sum_{u=0}^{N-1} \sum_{v=0}^{M-1} C_N(u)C_M(v) \tilde{I}(u, v) \cos\left[\frac{(2i+1)u\pi}{2N}\right] \cos\left[\frac{(2j+1)v\pi}{2M}\right]$$

where

$$C_N(u) = \begin{cases} 1/\sqrt{2} & ; u = 0 \\ 1 & ; u = 1, \dots, N-1 \end{cases}$$

DCT Basis Functions

- Displayed as 8 x 8 images:

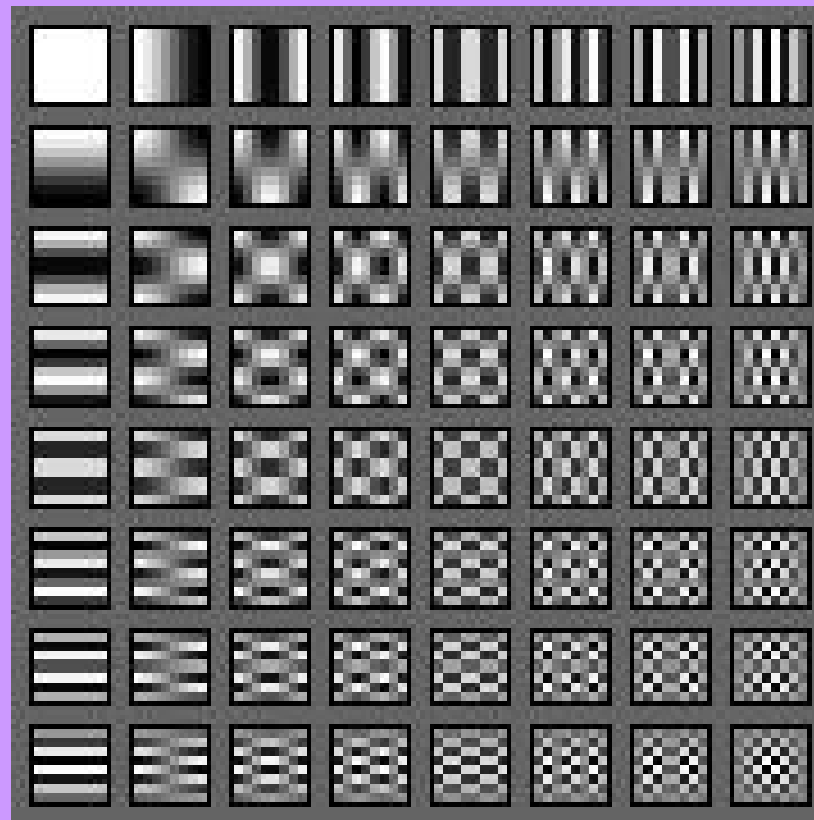

DCT vs. DFT

- JPEG is based on quantizing and re-organizing block DCT coefficients.
- The DCT is very similar to the DFT. **Why use the DCT?**
- First, $O(N^2 \log N^2)$ algorithms exist for DCT - slightly faster than DFT: all real, **integer-only** arithmetic.
- The DCT yields **better-quality compressed images** than the DFT, which suffers from more serious **block artifacts**.
- **Reason**: The DFT implies the image is N -periodic, whereas the DCT implies the **once-reflected image** is $2N$ -periodic.

Periodicity Implied by DFT

- A length- N (1-D) signal:

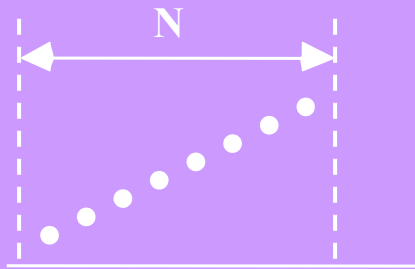

- **Periodic extension** implied by the DFT:



Periodicity Implied by DCT

- Periodic extension of **reflected signal** implied by the DCT:

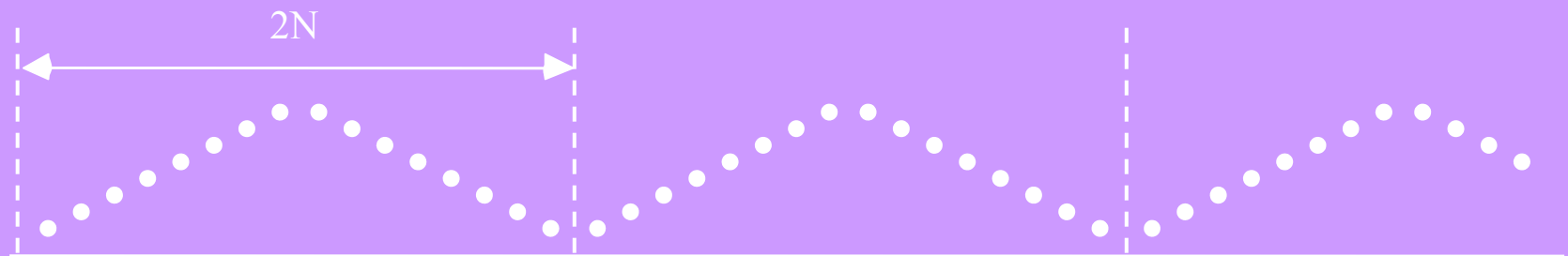

- **In fact** (good exercise): The DFT of the length- $2N$ reflected signal yields (two periods of) the DCT of the length- N signal.

Quality Advantage of DCT Over DFT

- The periodic extension of the DFT contains **high frequency discontinuities**.
- These high frequencies **must be well-represented** in the code, or the edge of the blocks will degrade, creating visible **blocking artifacts**.
- The DCT does **NOT** have meaningless discontinuities to represent - so less to encode, and so, **higher quality for a given CR**.

Overview of JPEG

- The commercial industry standard - formulated by the CCIT **Joint Photographic Experts Group** (JPEG).
- Uses the **DCT** as the central transform.
- Overall JPEG algorithm is **quite complex**. Three components:
 - JPEG baseline system** (basic lossy coding)
 - JPEG extended features (12-bit; progressive; arithmetic)
 - JPEG lossless coder

JPEG Standard Documentation

- The written standard is **gigantic**. Best resource (Pennebaker and Mitchell):

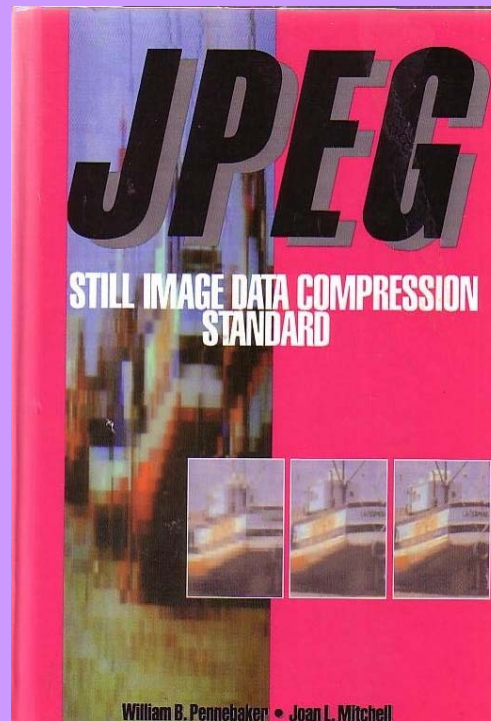

JPEG Baseline Flow Diagram

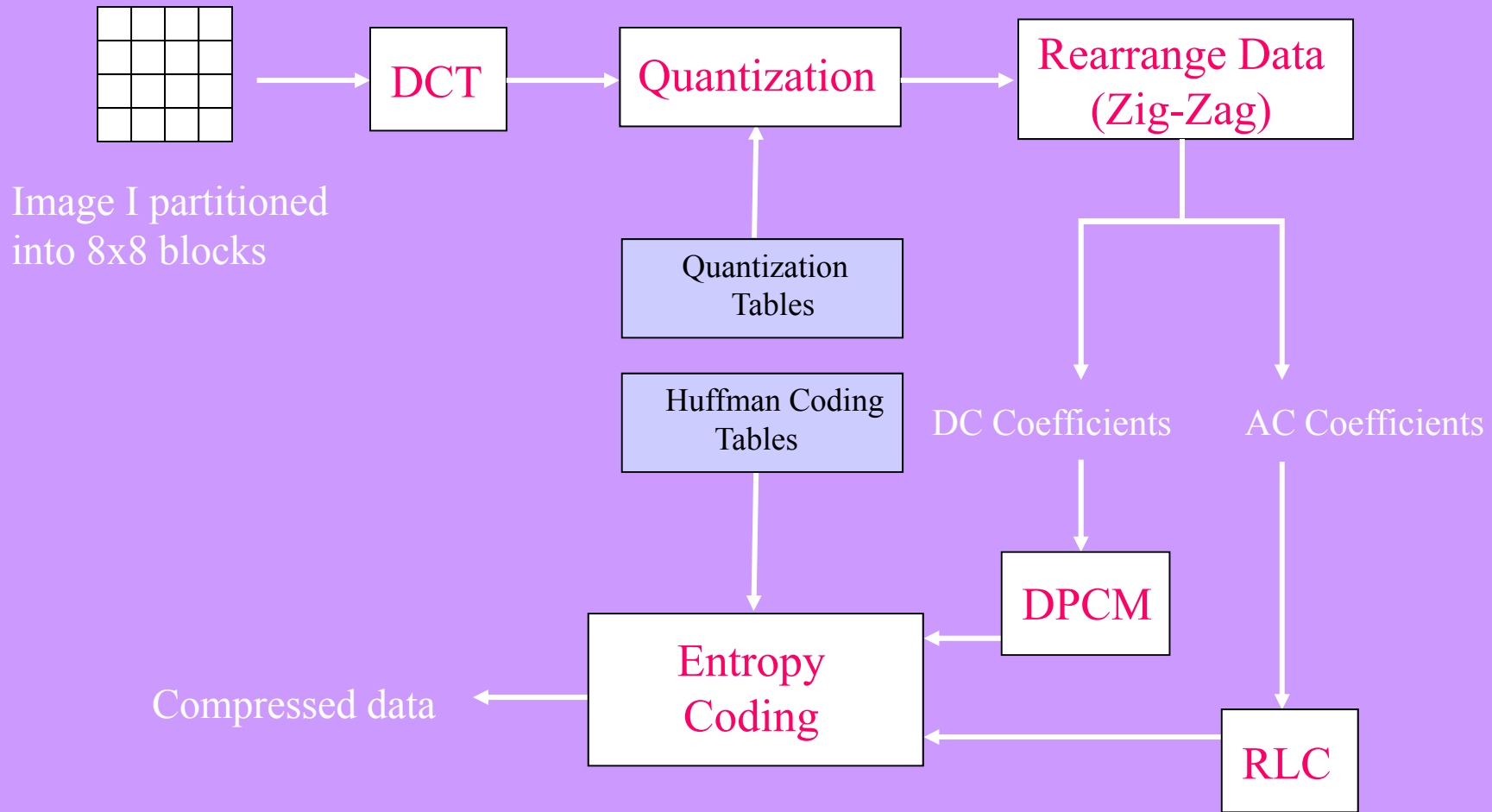

JPEG Baseline Algorithm

- (1) Partition image into **8 x 8 blocks**, transform each block using the DCT. Denote these blocks by: $\tilde{I}_k(u, v)$
- (2) Pointwise divide each block by an 8 x 8 **user-defined normalization array** $Q(u, v)$. This is **stored / transmitted** as part of the code. Usually designed using sensitivity properties of **human vision**.
- (3) The JPEG committee performed a human study on the **visibility of DCT basis functions** under a specific viewing model.

JPEG Baseline Algorithm

(3) **Uniformly quantize** the result

$$\tilde{I}_k^Q(u, v) = \text{INT} \left[\frac{\tilde{I}_k(u, v)}{Q(u, v)} + 0.5 \right]$$

yielding an **integer array** with **many zeros**.

JPEG Quantization Example

- A block DCT (via integer-only algorithm)

$$\tilde{\mathbf{I}}_k = \begin{bmatrix} 1260 & -1 & -12 & -5 & 2 & -2 & -3 & 1 \\ -23 & -17 & -6 & -3 & -3 & 0 & 0 & -1 \\ -11 & -9 & -2 & 2 & 0 & -1 & -1 & 0 \\ -7 & -2 & 0 & 1 & 1 & 0 & 0 & 0 \\ -1 & -1 & 1 & 2 & 0 & -1 & 1 & 1 \\ 2 & 0 & 2 & 0 & -1 & 1 & 1 & -1 \\ -1 & 0 & 0 & -1 & 0 & 2 & 1 & -1 \\ -3 & 2 & -4 & -2 & 2 & 1 & -1 & 0 \end{bmatrix}$$

- Typical JPEG normalization array:

$$\mathbf{Q} = \begin{bmatrix} 16 & 11 & 10 & 16 & 24 & 40 & 51 & 61 \\ 12 & 12 & 14 & 19 & 26 & 58 & 60 & 55 \\ 14 & 13 & 16 & 24 & 40 & 57 & 69 & 56 \\ 14 & 17 & 22 & 29 & 51 & 87 & 80 & 62 \\ 18 & 22 & 37 & 56 & 68 & 109 & 103 & 77 \\ 24 & 35 & 55 & 64 & 81 & 104 & 113 & 92 \\ 49 & 64 & 78 & 87 & 103 & 121 & 120 & 101 \\ 72 & 92 & 95 & 98 & 112 & 100 & 103 & 99 \end{bmatrix}$$

JPEG Quantization Example

- The resulting quantized DCT array:

$$\tilde{\mathbf{I}}_k^Q = \begin{bmatrix} 79 & 0 & -1 & 0 & 0 & 0 & 0 & 0 \\ -2 & -1 & 0 & 0 & 0 & 0 & 0 & 0 \\ -1 & -1 & 0 & 0 & 0 & 0 & 0 & 0 \\ 0 & 0 & 0 & 0 & 0 & 0 & 0 & 0 \\ 0 & 0 & 0 & 0 & 0 & 0 & 0 & 0 \\ 0 & 0 & 0 & 0 & 0 & 0 & 0 & 0 \\ 0 & 0 & 0 & 0 & 0 & 0 & 0 & 0 \\ 0 & 0 & 0 & 0 & 0 & 0 & 0 & 0 \end{bmatrix}$$

- Notice all the **zeros**. The **DC value** $\tilde{\mathbf{I}}_k^Q(0, 0)$ is in the upper left corner.
- This works because the DCT has **good energy compaction**, leading to a sparse image representation.

Data Re-Arrangement

- Rearrange quantized AC values

$$\tilde{I}_k^Q(u, v) ; (u, v) \neq (0, 0)$$

- This array contains **mostly zeros**, especially at high frequencies. So, rearrange the array into a 1-D vector using **zig-zag ordering**:

0	1	5	6	14	15	27	28
2	4	7	13	16	26	29	42
3	8	12	17	25	39	41	43
9	11	18	24	31	40	44	53
10	19	23	32	39	45	52	54
20	22	33	38	46	51	55	60
21	34	37	47	50	56	59	61
35	36	48	49	57	58	62	63

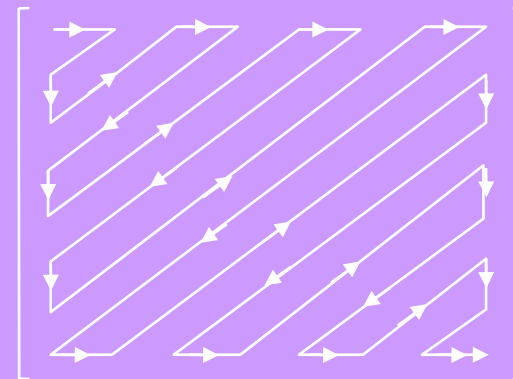

Data Re-Arrangement Example

- Reordered quantized block from the previous example:

[79 0 -2 -1 -1 -1 0 0 -1 (55 0's)]

- **Many** zeros.

Handling of DC Coefficients

- Apply **simple DPCM** to the **DC values** $\tilde{I}_k^Q(0, 0)$ between adjacent blocks to **reduce** the **DC entropy**.

- The **difference** between the current-block DC value and the left-adjacent-block DC value is found:

$$e(k) = \tilde{I}_k^Q(0, 0) - \tilde{I}_{k-1}^Q(0, 0)$$

- The differences $e(k)$ are losslessly coded by a **lossless JPEG Huffman coder** (with agreed-upon table).
- The first column of DC values must be retained to allow reconstruction.

Huffman Coding of DC Differences

<u>SSSS</u>	<u>DPCM difference</u>
0	0
1	-1,1
2	-3,-2,2,3
3	-7,...,-4,4,...,7
4	-15,...,-8,8,...,15
5	-31,...,-16,16,...,31
6	-63,...,-32,32,...,63
7	-127,...,-64,64,...,127
8	-255,...,-128,128,...,255
9	-511,...,-256,256,...,511
10	-1023,...,-512,512,...,1023
11	-2047,...,-1024,1024,...,2047
12	-4095,...,-2048,2048,...,4095
13	-8191,...,-4096,4096,...,8191
14	-16383,...,-8192,8192,...,16383
15	-32767,...,-16384,16384,...,32767
16	32768

- A Huffman Code is generated and stored/sent indicating which **category** (SSSS) the DC value falls in (See Pennebaker and Mitchell for the Huffman codes).
- SSSS is also the # bits allocated to code the DPCM differences and sign **80**

Run-Length Coding of AC Coefficients

- The AC vector contains **many** zeros.
- By using RLC considerable compression is attained.
- The AC vector is converted into 2-tuples (Skip, Value), where
 - **Skip** = number of zeros preceding a non-zero value
 - **Value** = the following non-zero value.
- When final non-zero value encountered, send (0,0) as **end-of-block**.

Huffman Coding of AC Values

<u>SSSS</u>	<u>AC coefficients</u>
1	-1,1
2	-3,-2,2,3
3	-7,...,-4,4,...,7
4	-15,...,-8,8,...,15
5	-31,...,-16,16,...,31
6	-63,...,-32,32,...,63
7	-127,...,-64,64,...,127
8	-255,...,-128,128,...,255
9	-511,...,-256,256,...,511
10	-1023,...,-512,512,...,1023
11	-2047,...,-1024,1024,...,2047
12	-4095,...,-2048,2048,...,4095
13	-8191,...,-4096,4096,...,8191
14	-16383,...,-8192,8192,...,16383
15	-32767,...,-16384,16384,...,32767

- The AC pairs (Skip, Value) are coded using **another** JPEG Huffman coder.
- A Huffman code represents which category (SSSS) the AC pair falls in.
- RRRR bits are used to represent the runlength of zeros, SSSS additional bits are used to represent the AC magnitude and sign.
- See Pennebaker and Mitchell for details!

JPEG Decoding

- **Decoding** is accomplished by reversing the Huffman coding, RLC and DPCM coding to recreate $\tilde{\mathbf{I}}_k^Q$
- Then **multiply by the normalization array** to create the lossy DCT

$$\tilde{\mathbf{I}}_k^{\text{lossy}} = \mathbf{Q} \otimes \tilde{\mathbf{I}}_k^Q$$

- The decoded image block is the IDCT of the result

$$\mathbf{I}_k^{\text{lossy}} = \text{IDCT} \left[\tilde{\mathbf{I}}_k^{\text{lossy}} \right]$$

JPEG Decoding

- The **overall compressed image** is recreated by putting together the compressed 8 x 8 pieces:

$$\mathbf{I}^{\text{lossy}} = \left[\mathbf{I}_k^{\text{lossy}} \right]$$

- The compressions that can be attained range over:
 - 8 : 1 (very high quality)
 - 16 : 1 (good quality)
 - 32 : 1 (poor quality for most applications)

JPEG Examples

Original
512 x 512
Barbara





16 : 1



JPEG 32:1

32 : 1



64 : 1

Original
512 x 512
Boats





JPEG 16:1

16 : 1



32 : 1



64 : 1

DEMO

COLOR JPEG

- Basically, RGB image is converted to YUV or YCrCb image (Y = intensity, UV or CrCb = chrominances – see Module 10)
- Each channel Y, U, V is **separately** JPEG-coded (no cross-channel coding)
- Chrominance images may be **subsampling** first
- Different quantization / normalization table may be used

JPEG Color Quantization Table

$$Q = \begin{bmatrix} 17 & 18 & 24 & 47 & 99 & 99 & 99 & 99 \\ 18 & 21 & 26 & 66 & 99 & 99 & 99 & 99 \\ 24 & 26 & 56 & 99 & 99 & 99 & 99 & 99 \\ 47 & 66 & 99 & 99 & 99 & 99 & 99 & 99 \\ 99 & 99 & 99 & 99 & 99 & 99 & 99 & 99 \\ 99 & 99 & 99 & 99 & 99 & 99 & 99 & 99 \\ 99 & 99 & 99 & 99 & 99 & 99 & 99 & 99 \\ 99 & 99 & 99 & 99 & 99 & 99 & 99 & 99 \end{bmatrix}$$

- **Sparser sampling** and more **severe quantization** of the chrominance values is acceptable.
- Color is primarily a **regional attribute** and contains less detail information.

Wavelet Image Compression

Wavelet Image Coding

- **Idea:** Compress images in the wavelet domain.
- Image blocks are not used. Hence: **no blocking artifacts!**
- Forms the basis of the **JPEG2000 standard**.
- Also requires **perfect reconstruction** filter banks.

Compression Via DWT

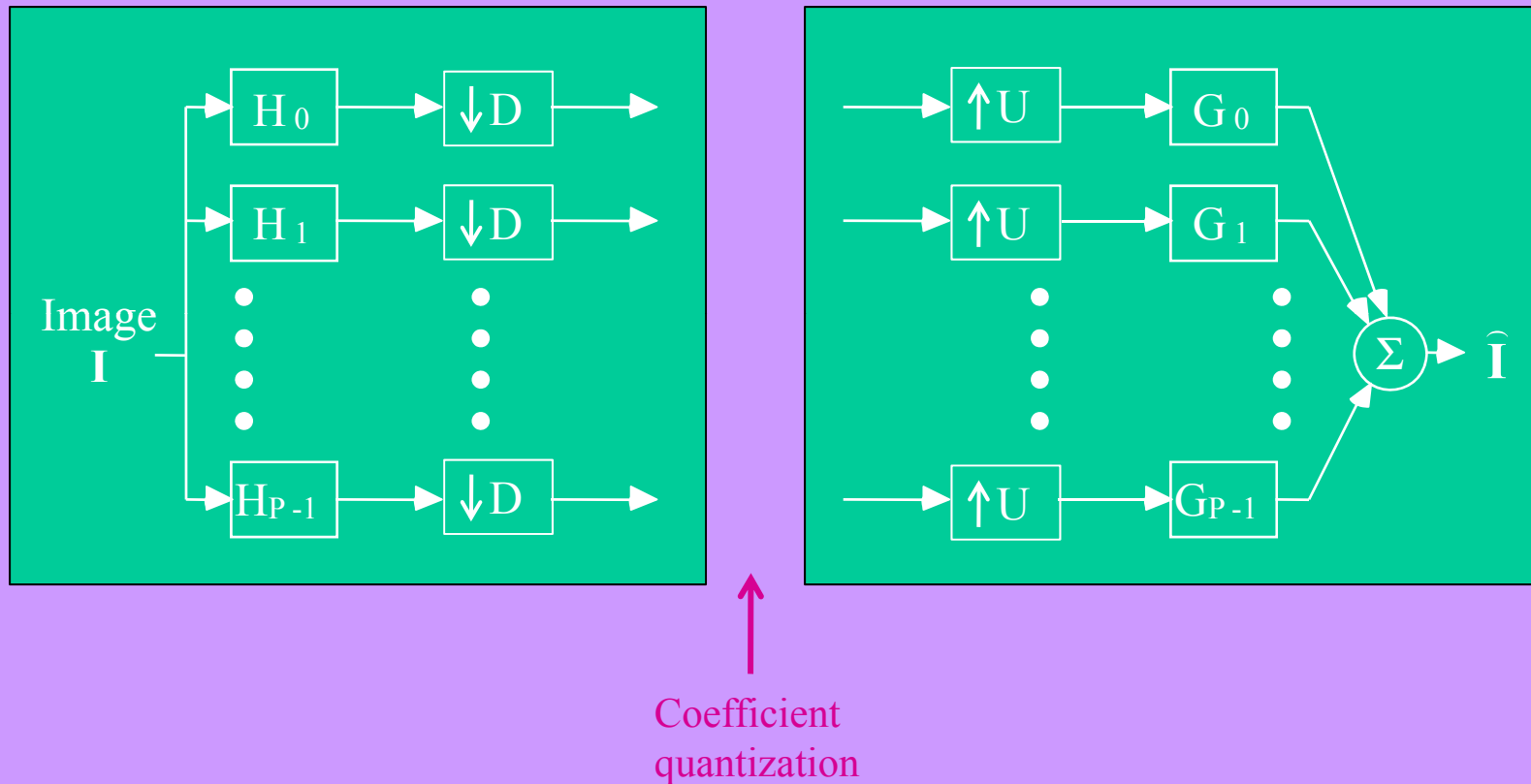

Filters H_p form a **orthogonal or bi-orthogonal basis** with reconstruction filters G_p .

Wavelet Decompositions

- Recall that wavelet filters **separate or decompose** the image into high- and low-frequency bands, called **subbands**. Each frequency band can be coded **separately**.

(0, 0)

Low, Low	High, Low
Low, High	High, High

- These are called **quadrature filters**.

Wavelet Decompositions

- Typically frequency division is done iteratively on the **lowest-frequency bands**:

(0, 0)

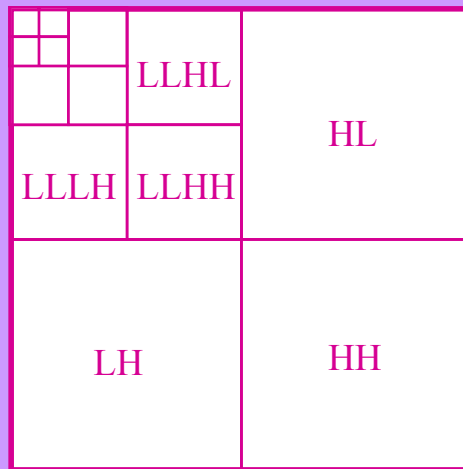

"Pyramid" Wavelet Transform

(0, 0)

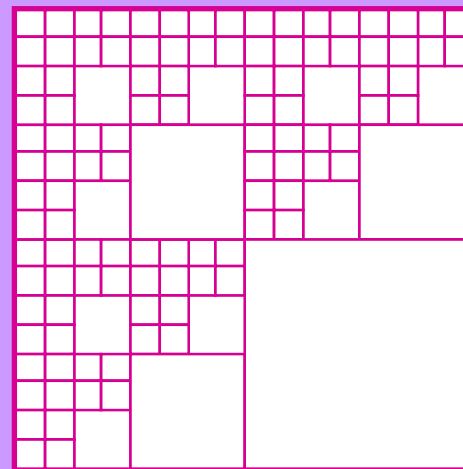

"Tree-Structured" Wavelet Transform

Bi-Orthogonal Wavelets

- Recall the **perfect reconstruction condition**:

$$\underline{H}_0(\omega)\underline{G}_0(\omega) + \underline{H}_1(\omega)\underline{G}_1(\omega) = 2 \quad \text{for all } 0 \leq \omega \leq \pi \quad (\text{DSFT})$$

$$\text{hence also } \tilde{H}_0(u)\tilde{G}_0(u) + \tilde{H}_1(u)\tilde{G}_1(u) = 2 \quad \text{for all } 0 \leq u \leq N-1 \quad (\text{DFT})$$

and

$$\underline{H}_0(\omega+\pi)\underline{G}_0(\omega) + \underline{H}_1(\omega+\pi)\underline{G}_1(\omega) = 0 \quad \text{for all } 0 \leq \omega \leq \pi \quad (\text{DSFT})$$

$$\text{hence also } \tilde{H}_0(u+N/2)\tilde{G}_0(u) + \tilde{H}_1(u+N/2)\tilde{G}_1(u) = 0 \quad \text{for all } 0 \leq u \leq N-1 \quad (\text{DFT})$$

- The filters H_0, H_1, G_0, G_1 can be either **orthogonal quadrature mirror filters**, or they can be bi-orthogonal

$$\sum_{i=1}^{N-1} H_n(i) G_m(i) = \begin{cases} 1; m = n \\ 0; m \neq n \end{cases}$$

for all $m, n = 0, 1$.

Bi-Orthogonal Wavelets

- Bi-orthogonal wavelets **are useful since they can be made even-symmetric.**
- This is important because much **better results** can be obtained in **image compression.**
- Even though they **do not** have as **good energy compaction** as **orthogonal wavelets.**

Bi-Orthogonal Wavelets

- Wavelet based image compression usually operates on **large image blocks** (e.g., 64x64 in JPEG2000)
- It is much more efficient to realize block DWTs using **cyclic convolutions** (shorter).
- As with the DCT, **symmetric extended** signals (without discontinuities) give better results than **periodic extended**.
- **Symmetric wavelets** give **better approximations to symmetric extended** signals.
- There are **standard bi-orthogonal wavelets**.

Daubechies 9/7 Bi-Orthogonal Wavelets

Analysis LP

$H_0(0) = 0.026749$
 $H_0(1) = -0.016864$
 $H_0(2) = -0.078223$
 $H_0(3) = 0.266864$
 $H_0(4) = 0.602949$
 $H_0(5) = 0.266864$
 $H_0(6) = -0.078223$
 $H_0(7) = -0.016864$
 $H_0(8) = 0.026749$



Analysis HP

$H_1(0) = 0$
 $H_1(1) = 0.091272$
 $H_1(2) = -0.05754$
 $H_1(3) = -0.59127$
 $H_1(4) = 1.115087$
 $H_1(5) = -0.59127$
 $H_1(6) = -0.05754$
 $H_1(7) = 0.091272$
 $H_1(8) = 0$

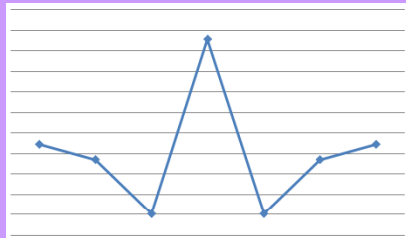

Synthesis LP

$G_0(0) = 0$
 $G_0(1) = -0.091272$
 $G_0(2) = -0.05754$
 $G_0(3) = 0.59127$
 $G_0(4) = 1.115087$
 $G_0(5) = 0.59127$
 $G_0(6) = -0.05754$
 $G_0(7) = -0.091272$
 $G_0(8) = 0$

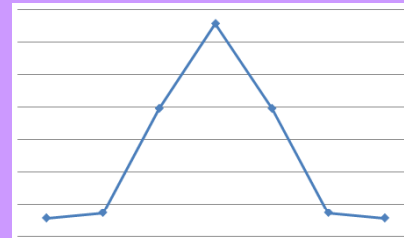

Synthesis HP

$G_1(0) = 0.026749$
 $G_1(1) = 0.016864$
 $G_1(2) = -0.078223$
 $G_1(3) = -0.266864$
 $G_1(4) = 0.602949$
 $G_1(5) = -0.266864$
 $G_1(6) = -0.078223$
 $G_1(7) = 0.016864$
 $G_1(8) = 0.026749$

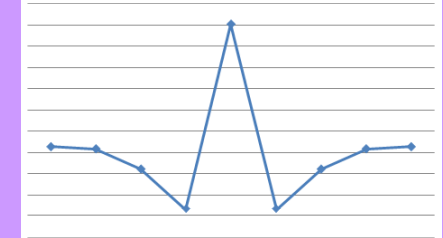

These are used in the **JPEG2000 standard.**

D9/7 DWT of an Image

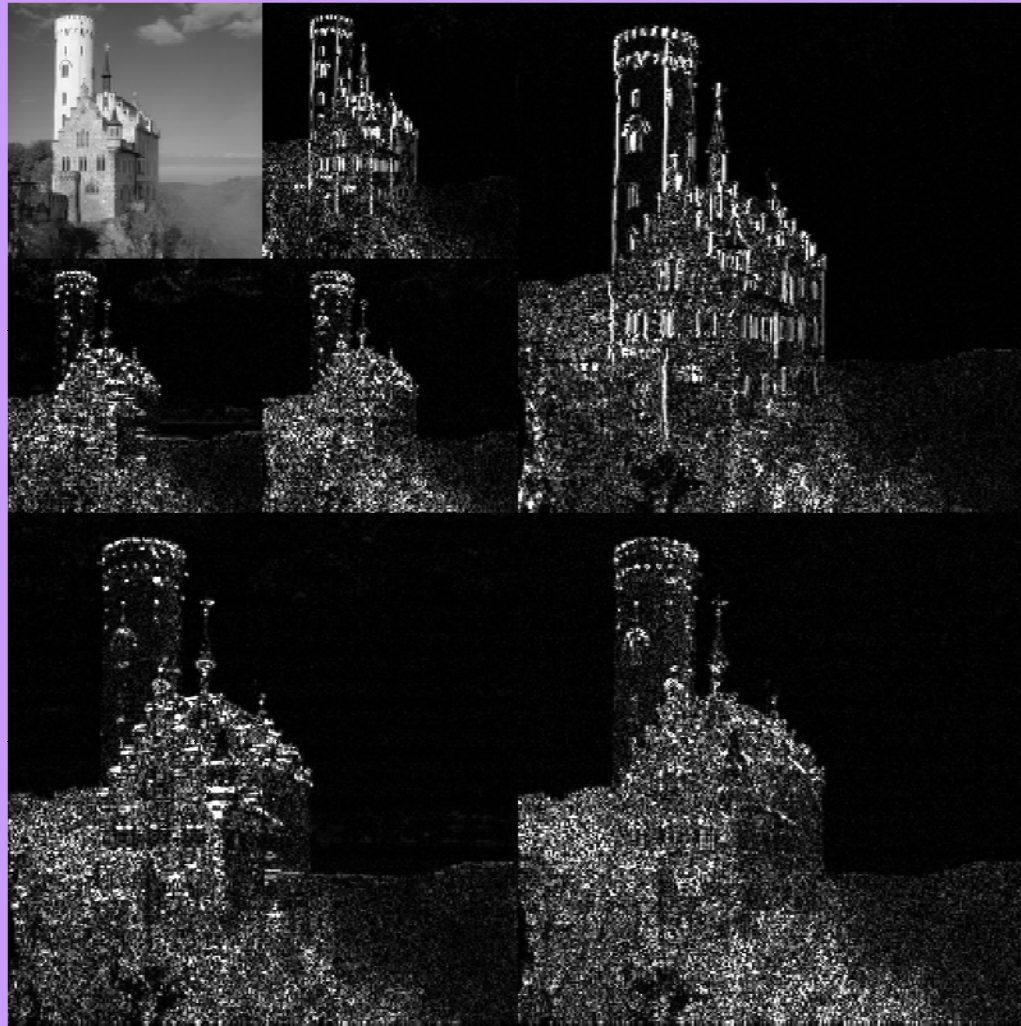

JPEG2000

- **Too complex** to go into depth, and **not widely-accepted** enough to spend much time on.
- **Advantages:**
 - Better compression at low bitrates
 - Scalable (can truncate bitstream at any point)
 - No Blocking artifacts
- **Disadvantages:**
 - Complex encoders/decoders
 - Only slightly better compression at high bitrates
 - Ringing artifacts

JPEG2000

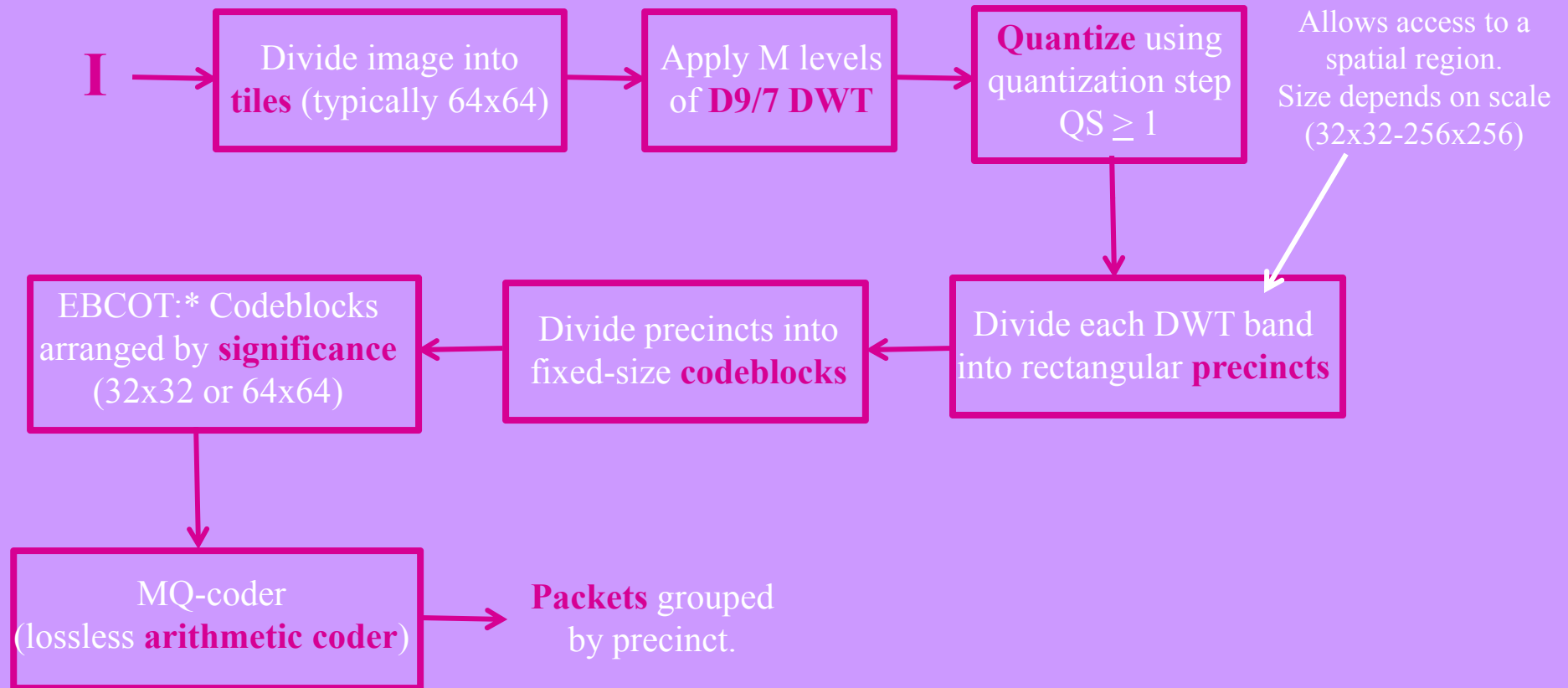

*Embedded Block Coding with Optimal Truncation

Wavelet Decoding

- **Decoding** requires
 - Decompression of the wavelet coefficients
 - Reconstructing the image from the decoded coefficients:

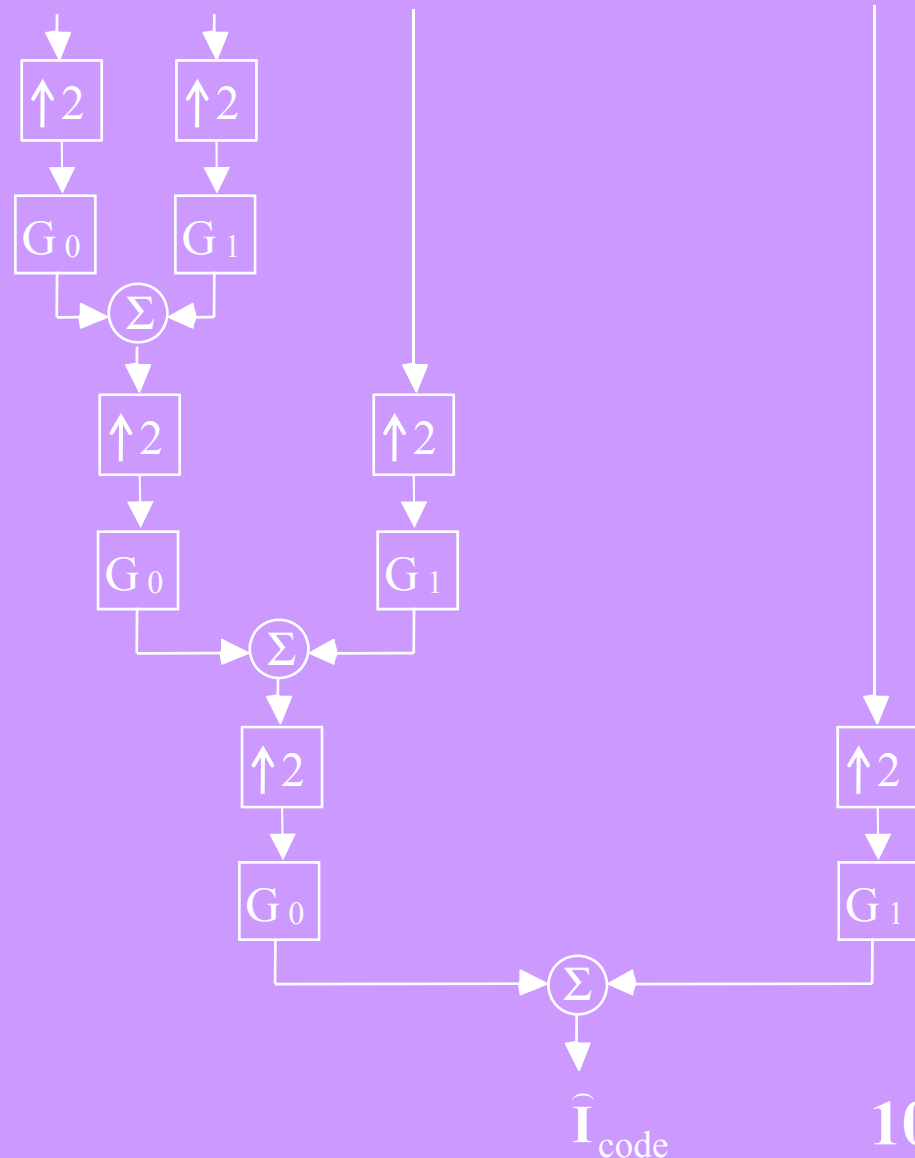

JPEG2000 Wavelet Compression Example

Original
512 x 512
Barbara





WAV 16:1

16:1



WAV 32:1

32 : 1



64 : 1



128 : 1

Original
512 x 512
Boats





16 : 1



WAV 32:1

32 : 1



64 : 1



128 : 1

Comments on Wavelet Compression

- This has been a **watered-down** exposition of wavelet coding!
- **Reason:** there has not yet been much adoption of JPEG2000.
- Why? It is **vastly** more complex than “old” JPEG. A consideration in an era of **cheap memory**.
- There are questions of **propriety**.
- It’s performance is primarily better in the **high compression** regime.

- If interested....

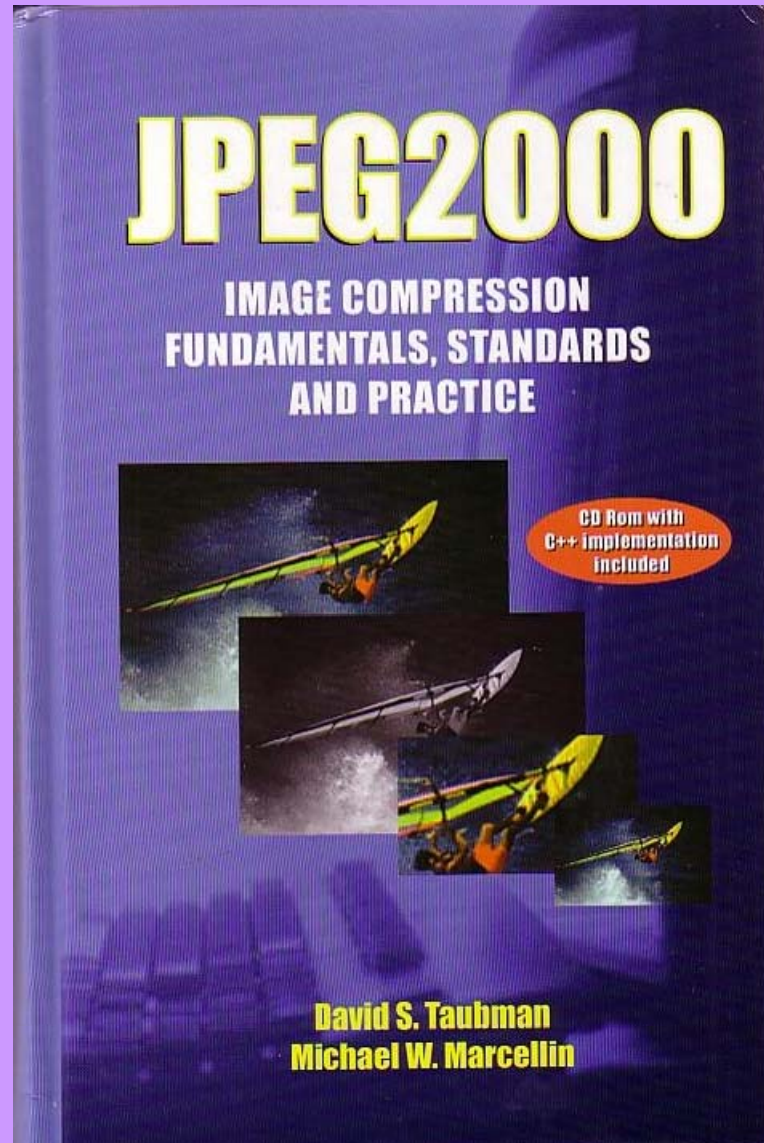

Comments

- So far we have been **processing images** – now we will try to **understand** them – **image analysis** ... onward to **Module 7**.